

# KOMPAKTNÍ SVÍTLA PRO ELEKTRICKÉ TROUBY

Typ 1233-.... Objímka keramická E14, T300

# COMPACT LIGHTINGS FOR ELECTRICAL OVENS

Type 1233-.... Ceramic lampholder E14, T300

	Rozměry svítidla [mm] Light dimensions [mm]	Technické parametry Technical parameters	Hmotnost Weight	Typové číslo Type number	Balení Packing
		15W, 250V	90 g	1233-607F	126 ks
		25W, 250V	92 g	1233-617F	126 ks
		15W, 250V	93 g	1233-608F	126 ks
		25W, 250V	95 g	1233-618F	126 ks
		15W, 250V	90 g	1233-609F	126 ks
		25W, 250V	92 g	1233-619F	126 ks
		25W, 250V	108 g	1233-617E	90 ks
		25W, 250V	111 g	1233-618E	90 ks
		25W, 250V	108 g	1233-619E	90 ks

## KOMPAKTNÍ SVÍTIDLA PRO ELEKTRICKÉ TROUBY

Typ 1234—... Objímka keramická E14, T300

## COMPACT LIGHTINGS FOR ELECTRICAL OVENS

Type 1234—... Ceramic lampholder E14, T300

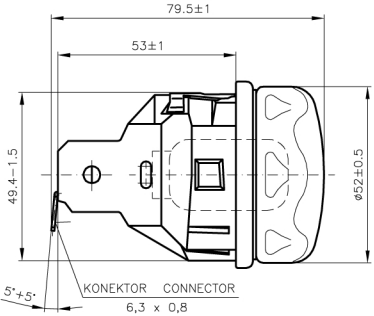

	Rozměry svítidla [mm] Light dimensions [mm]	Technické parametry Technical parameters	Hmotnost Weight	Typové číslo Type number	
		15W, 250V	122,5 g	1234-606	70 ks
		25W, 250V	124,5 g	1234-616	70 ks

## HALOGENOVÁ KOMPAKTNÍ SVÍTIDLA PRO ELEKTRICKÉ TROUBY

Typ 1532—.... Objímka keramická G9, T350

## HALOGEN COMPACT LIGHTINGS FOR ELECTRICAL OVENS

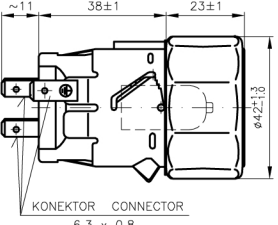
Type 1532—.... Ceramic lampholder G9, T350

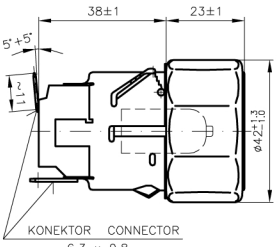

	Rozměry svítidla [mm] Light dimensions [mm]	Technické parametry Technical parameters	Hmotnost Weight	Typové číslo Type number	Balení Packing
		25W, 250V	83 g	1532-617F	126 ks
		40W, 250V	83 g	1532-627F	126 ks
		60W, 250V	83 g	1532-637F	126 ks
		25W, 250V	83 g	1532-619F	126 ks
		40W, 250V	83 g	1532-629F	126 ks
		60W, 250V	83 g	1532-639F	126 ks

# HALOGENOVÁ KOMPAKTNÍ SVÍTIDLA PRO ELEKTRICKÉ TROUBY

1534-... Objímka keramická G9, T350

# HALOGEN COMPACT LIGHTINGS FOR ELECTRICAL OVENS

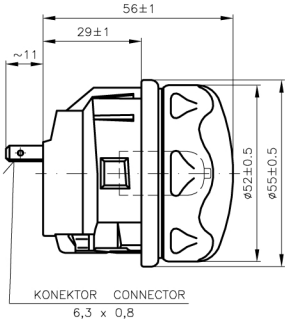
Type 1534-... Ceramic lampholder G9, T350

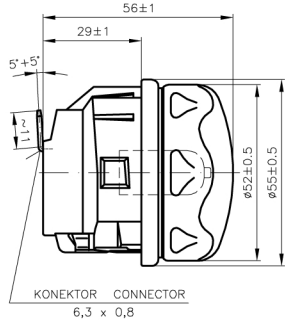
	Rozměry svítidla [mm] Light dimensions [mm]	Technické parametry Technical parameters	Hmotnost Weight	Typové číslo Type number	Balení Packing
		25W, 250V	126 g	1534-617	70 ks
		40W, 250V	126 g	1534-627	70 ks
		60W, 250V	126 g	1534-637	70 ks
		25W, 250V	126 g	1534-619	70 ks
		40W, 250V	126 g	1534-629	70 ks
		60W, 250V	126 g	1534-639	70 ks

## Zástavbové rozměry otvoru [mm] Building up dimensions of opening [mm]

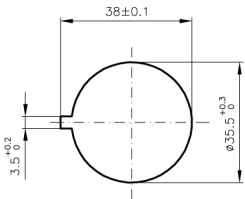
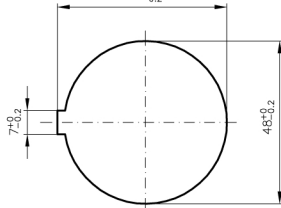
1233-.... ; 1532-....	1234-... ; 1534-...
 <p>PANEL-PLECH t=1±2,5 PANEL-METAL SHEET t=1±2,5</p>	 <p>PANEL-PLECH t=0,8±2 PANEL-METAL SHEET t=0,8±2</p>

Výrobky uvedené v nabídce jsou v souladu s evropskou direktivou 2006/95/EC včetně dodatků a jsou certifikovány dle normy EN 60238 (IEC 60238) nebo EN 60838-1 (IEC 60838-1). Shodu ověřil Elektrotechnický zkušební ústav Praha nebo VDE Prüf- und Zertifizierungsinstitut Offenbach. Na výrobky jsou vystaveny certifikáty CB, VDE nebo ESČ.

Po dohodě zákazníka s výrobcem je možno zrealizovat různé modifikace kompaktních svítidel.

The products are in accordance with the european directive 2006/95/EC including amendments and are certified according to the norm EN 60238 (IEC 60238) or EN 60838-1 (IEC 60838-1). The conformity was verified by the Elektrotechnický zkušební ústav Praha or the VDE Prüf- und Zertifizierungsinstitut Offenbach. The products have CB, VDE or ESČ certification.

In agreement with the customer and the producer is possible to implement various modifications of compact lights.